

THIS DRAWING IS UNPUBLISHED. RELEASED FOR PUBLICATION
 © COPYRIGHT BY TYCO ELECTRONICS CORPORATION. ALL RIGHTS RESERVED.

LOC	DIST	REVISIONS					
GP	00	P	LTR	DESCRIPTION	DATE	DWN	APVD
		U		REVISED PER ECO-08-005709	18FEB08	JDP	CWR

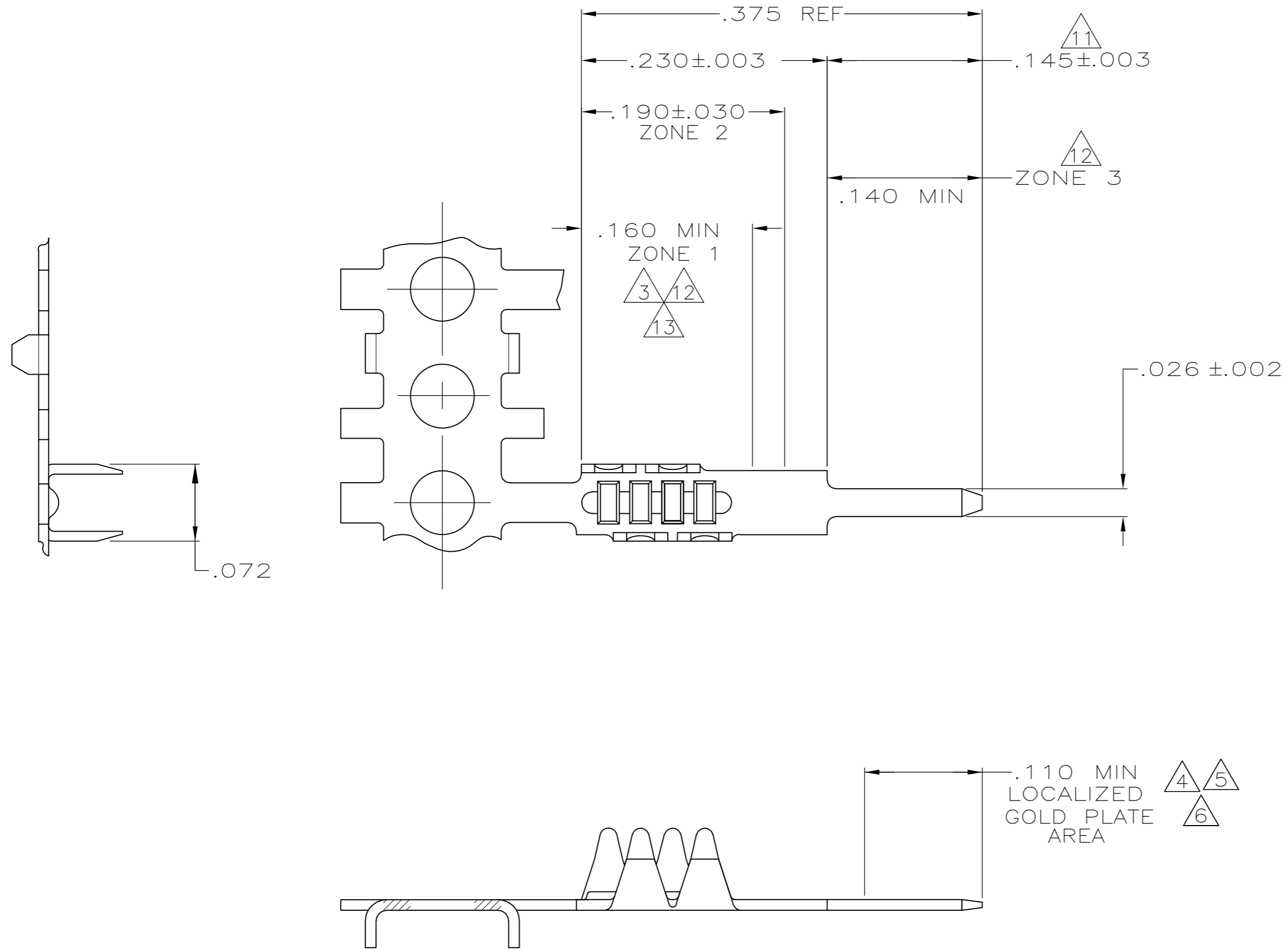

- 1 .000050 MIN THK NICKEL UNDERPLATE OVER ENTIRE CONTACT.
- 2 .000150 MIN BRIGHT TIN/LEAD OVER ENTIRE CONTACT.
- 3 .000100 MIN THK BRIGHT TIN/LEAD IN ZONE 1.
- 4 GOLD FLASH IN LOCALIZED GOLD PLATE AREA.
- 5 .000015 MIN GOLD IN LOCALIZED GOLD PLATE AREA
- 6 .000030 MIN GOLD IN LOCALIZED GOLD PLATE AREA
- 7. TO BE APPLIED PER AMP APPLICATION SPEC 114-16015.
- 8. RECOMMENDED HOLE SIZE IS .031-.035 DIA.
- 9 FOR SOLDERABILITY SEE AMP PRODUCT SPEC 108-9024.
- 10 .000150 MIN TIN-LEAD IN ZONE 2.
- 11 AREA TO BE UNPLATED (-9 ONLY).
- 12 GOLD FLASH IN ZONE 1. .000150 MIN TIN IN ZONE 3.
- 13 GOLD FLASH IN ZONE 1.

.110 MIN LOCALIZED GOLD PLATE AREA

	1 6 13	1-88997-4
	1 5 13	1-88997-3
	1 9 12	1-88997-2
OBSOLETE	10 11	88997-9
	1 3 6	88997-5
	1 3 5	88997-4
SUPERSEDED BY 88997-5	1 3 4	88997-3
	1 2 9	88997-2
	FINISH	PART NO

THIS DRAWING IS A CONTROLLED DOCUMENT.		DWN	B. MCMASTER	10MAR04	Tyco Electronics Corporation Harrisburg, Pa 17105-3608
DIMENSIONS: INCHES		CHK	S. BOLASH	10MAR04	
TOLERANCES UNLESS OTHERWISE SPECIFIED:		APVD	M. WALMSLEY	10MAR04	NAME
0 PLC ± -		PRODUCT SPEC		CONTACT, SOLDER	
1 PLC ± -		108-9024		TAB, FFC, .100 Φ	
2 PLC ± -		APPLICATION SPEC		SIZE CAGE CODE DRAWING NO	
3 PLC ± .005		114-16015		A2 00779 C=88997	
4 PLC ± -		WEIGHT		RESTRICTED TO	
ANGLES ± -		-		-	
FINISH		SEE TABLE		SCALE 10:1 SHEET 1 OF 1 REV U	
MATERIAL		CUSTOMER DRAWING			
PH. BRONZE .010 THK					